

# WILD HORSES

## FOUR WHEEL DRIVE

Phone (209) 400-7200 Fax (209) 943-7923 www.wildhorses4x4.com

### Windshield Wiper Kit

#5298/5301 Date 12/08/17 rev.1

#### Parts

2 wiper motors  
1 wiper switch

#### Hardware

2 ea. self tapping screws  
2 ea. motor nuts and washers

**Please read entire instruction sheet before you get started based on how you proceed some steps may be out of sequential order.** All wiper motors are set at 110 degrees on the degree wheel. If you are installing this kit on a 66-68 windshield frame you must change the degree setting to 80 degrees on the passenger side wiper motor. (only the passenger side needs to be set to the 80 degree setting)

Instructions for changing degree.

Instructions for changing degree. See diagram to the right.

1. Remove the four (4) screws from the back plate of the wiper motor.
2. Remove the U-clip from the actuator arm.
3. Remove the actuator arm from the degree wheel.
4. Remove the two phillips screws holding the degree wheel.
5. Move the degree wheel and place the arm in the 80 degree position.
6. Install phillips screws, actuator arm, u-clip and cover.

#### Mounting wiper motors

1. Remove the old wiper setup.
2. Remove the old vacuum hose 66-68, or wiper wiring 69-77, from the windshield frame. The windshield frame must be lowered forward.
3. Position wiper motors so that the round portion of the motor housing is towards the passenger side.
4. Insert the wiper shaft into windshield frame, on 66-68 frames you may need to file or drill out the hole for the wiper motor shafts to fit through the windshield frame. Attach the nut and washer. Tighten the nut to 30-50 in. lbs.
5. Use the supplied self tapping screws to secure the motor mounting tab to the windshield frame.

#### Wiring see figure 2 on back of this sheet.

Note 14-16 gauge wire is recommended. A 5 amp fuse needs to be placed between the battery and the wiper switch.

Our wiper switch is equipped with a push button for the windshield washers. For the 66-68 you must connect the old washer pump button wire to the washer pump wire on the new switch. If you have a 69-77 Bronco you must connect the green wire from the old wiper switch to the washer pump wire on the new switch.

**Getting the wiring through the frame.** Patience grasshopper. Fishing the wires through the windshield frame is a pain to say the least but it can be done. You might be able to use the old wiring or vacuum tube to help pull the new wiring through.

**For switch operation see switch manual.**

View from back of motor

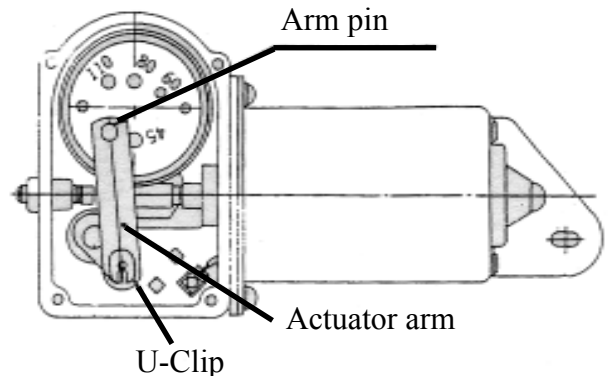

This pic shows orientation of motor on windshield frame.

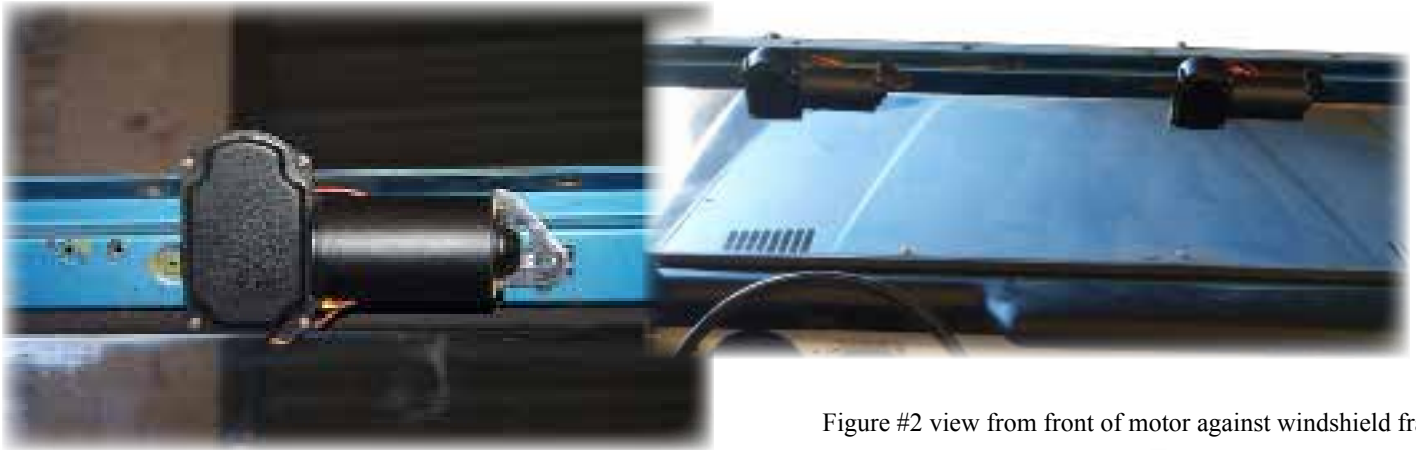

Figure #2 view from front of motor against windshield frame

